

Membrane Air Dryer Single Unit Type Series *IDG*

Single Unit/Standard Dew Point -20°C Specifications

How to Order

IDG 10 — **03** —

Flow rate by size

Size	Outlet air flow rate Purge air flow rate	ℓ/min (ANR)
1	10/2.5	
3	25/6	
5	50/12	
10	100/25	
20	200/50	
30	300/75	
50	500/125	
60	600/125	
75	750/150	
100	1000/190	

Thread type

Symbol	Contents
Nil	Rc
N	NPT
F	G

Option

Symbol	Contents	Size									
		1	3	5	10	20	30	50	60	75	100
Nil	None (Standard)	●	●	●	●	●	●	●	●	●	●
P	With fitting for purge air discharge	●	●	●	●	●	●	●	●	●	●
R	Flow direction (Right → Left)	—	●	●	●	●	●	●	●	●	●
S	With dew point indicator	—	●	●	—	—	—	—	—	—	—

Note) In the case of two or more options, indicate them alphabetically.

Accessory

Symbol	Contents
Nil	None (Standard)
B	With bracket (Except IDG1)

Note) When symbol B is indicated, a bracket assembly with a part number shown in the table below is included as an accessory.

Port size

Symbol	Bore	Size									
		1	3	5	10	20	30	50	60	75	100
01	1/8	—	●	●	—	—	—	—	—	—	—
02	1/4	●	●	●	●	●	●	—	—	—	—
03	3/8	—	—	—	●	●	●	●	—	—	—
04	1/2	—	—	—	—	—	—	●	●	●	—

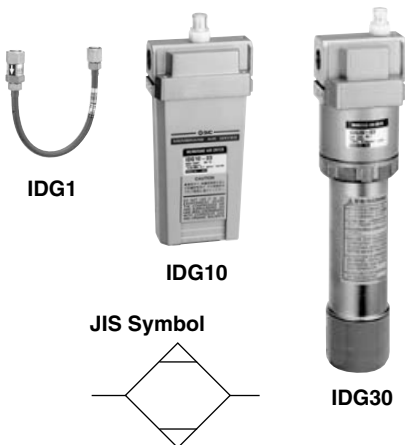

Standard Specifications/Single Unit Type (Standard dew point: -20°C)

Model		Standard dew point: -20°C									
		IDG1	IDG3	IDG5	IDG10	IDG20	IDG30	IDG50	IDG60	IDG75	IDG100
Range of operating conditions	Fluid	Compressed air									
	Inlet air pressure (MPa)	0.3 to 0.85					0.3 to 1.0				
	Inlet air temperature ($^{\circ}\text{C}$) ⁽¹⁾	-5 to 55					-5 to 50				
	Ambient temperature ($^{\circ}\text{C}$)	-5 to 55					-5 to 50				
Standard performance	Outlet air atmospheric pressure dew point ($^{\circ}\text{C}$)	-20									
Standard performance conditions	Inlet air flow rate (ℓ/min (ANR)) ⁽²⁾	12.5	31	62	125	250	375	625	725	900	1190
	Outlet air flow rate (ℓ/min (ANR))	10	25	50	100	200	300	500	600	750	1000
	Purge air flow rate (ℓ/min (ANR)) ⁽³⁾	2.5	6	12	25	50	75	125	125	150	190
	Inlet air pressure (MPa)	0.7									
	Inlet air temperature ($^{\circ}\text{C}$)	25									
	Inlet air saturation temperature ($^{\circ}\text{C}$)	25									
Dew point indicator purge air flow rate		—			1 ℓ/min (ANR) {In case of Inlet air pressure 0.7 MPa}						
Port size (Nominal size B)		1/4	1/8, 1/4	1/4, 3/8			3/8, 1/2		1/2		
Weight (kg) (With bracket)		0.11	0.25 (0.31)	0.43 (0.51)	0.66 (0.76)	0.74 (0.87)	0.77 (0.90)	1.50 (1.65)	1.50 (1.65)	1.55 (1.70)	—

Bracket Assembly (Accessory) Part No.

Part no.	Applicable model
BM59	IDG3, 5
BM61	IDG10
BM63	IDG20
BM64	IDG30/50
BM65	IDG60/75/100

* With cap bolts and spring washers

Note 1) No freezing.

Note 2) ANR indicates the flow rate converted to the value at 20°C under the atmospheric pressure and the state of relative humidity 65%.

Note 3) Includes 1 ℓ/min (ANR) of purge air flow (at 0.7 MPa inlet air pressure) for the dew point indicator (except IDG1, 3, 5).

Performance Chart

Conditions: Inlet air temperature 25°C (saturated air), Ambient temperature 25°C, P₁: Inlet air pressure, Tube for purge air discharge (Option: P): None
 Notice: In the case of products with fitting for purge air discharge (Option: P), refer to page 14-19-18.
 Product groups inside parentheses in the graph are classification symbols for selecting a model. (Refer to page 14-19-11.)

IDG1 (Type A products group)

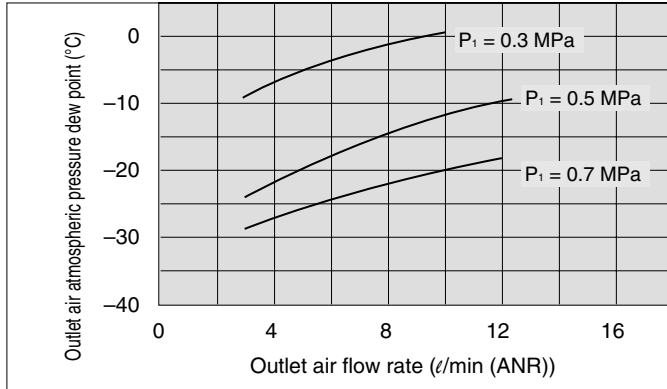

IDG3 (Type A products group)

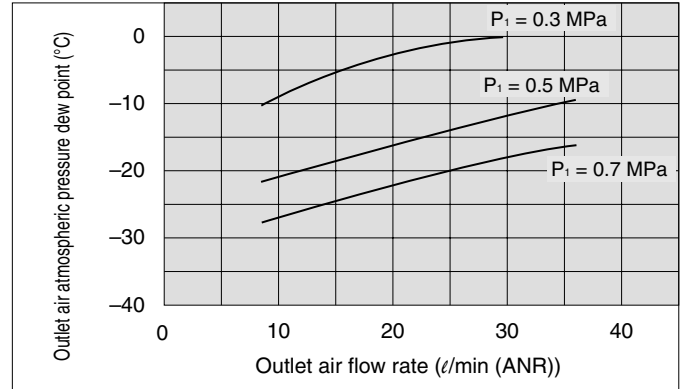

IDG5 (Type A products group)

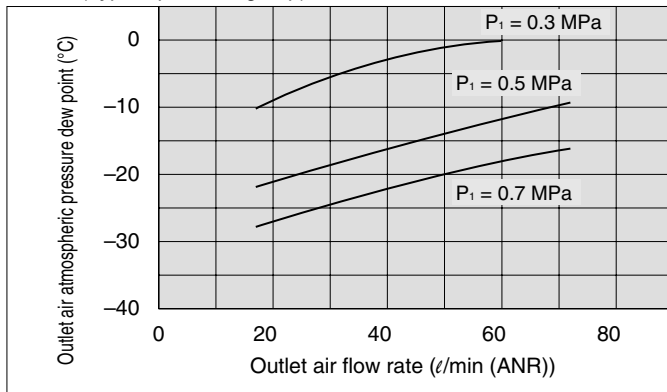

IDG10 (Type A product group)

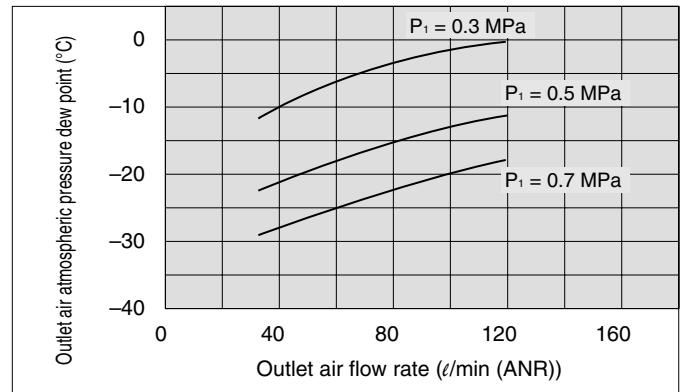

IDG20 (Type A products group)

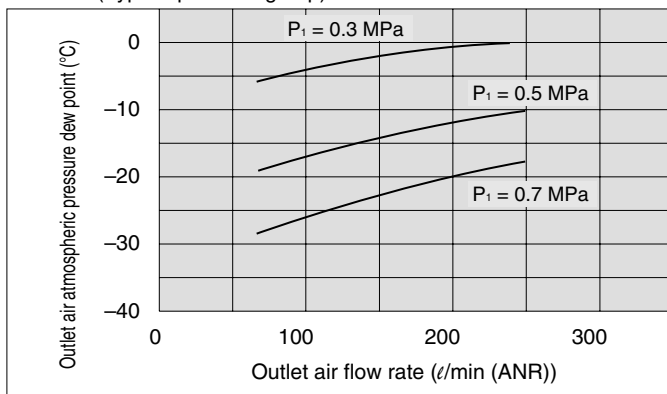

IDG30 (Type B products group)

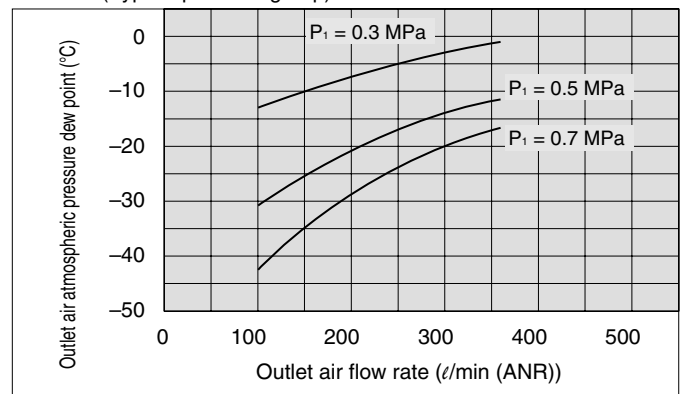

IDG50 (Type B products group)

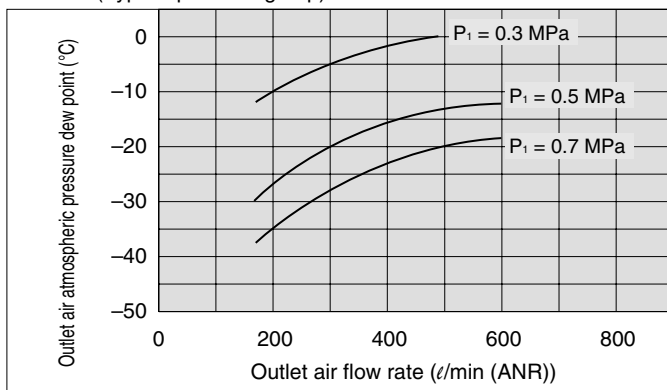

IDG60 (Type A products group)

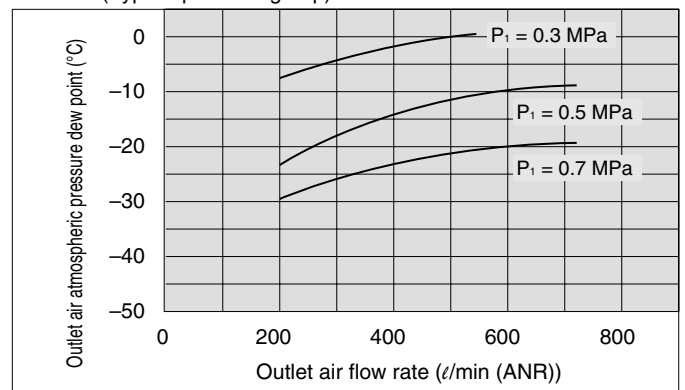

HA

AT

ID

AMG

AFF

AM

Misc.

Series IDG

Performance Chart

Conditions: Inlet air temperature 25°C (saturated air), Ambient temperature 25°C, P₁: Inlet air pressure

IDG75 (Type A products group)

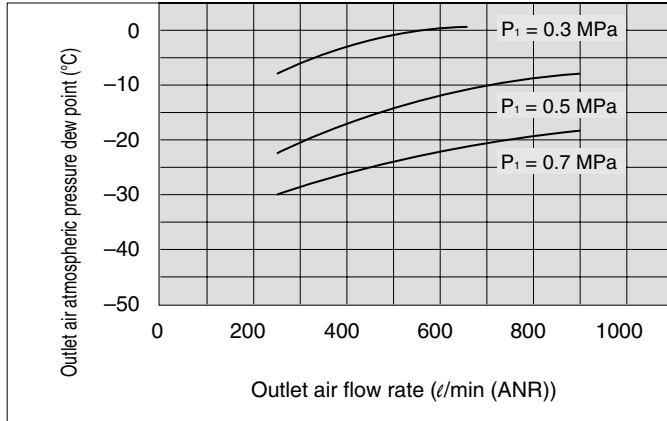

IDG100 (Type A products group)

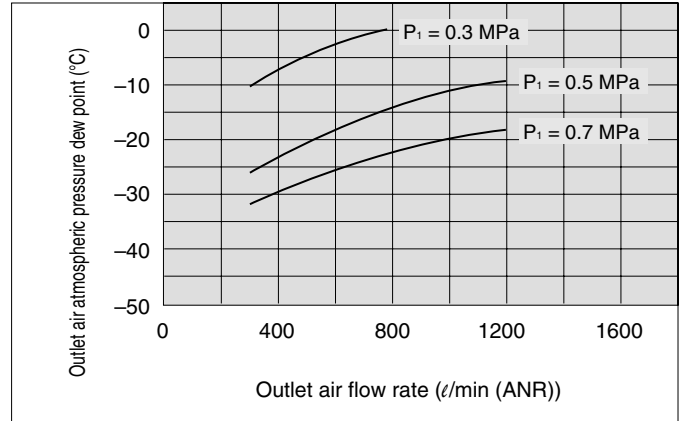

With fittings for purge air discharge (Option: P)

As the length of tubing for purge air discharge becomes longer, the outlet air atmospheric pressure dew point becomes higher. Refer to the table below.

Outlet Air at the Atmospheric Pressure Dew point in Compliance with the Tube Length for Discharging the Purged Air (°C)

Tube length	Model	IDG30	IDG50
0 m		-20	
1 m		-19	
3 m		-17	
5 m		-16	

Note) In cases other than above model numbers, if the tube length is 5 m or less, an increase of the outlet air at the atmospheric pressure dew point will be 1°C or less.

■ Conditions

- Inlet air temperature : 25°C (Saturated)
- Ambient temperature : 25°C
- Inlet air pressure : 0.7 MPa
- Outlet air flow rate : Flow gained under conditions of the standard performance. (Refer to page 14-19-16.)
- Tubing size (O.D. x I.D.) mm: ø12 x ø9

Construction

Refer to pages 14-19-28 to 29.

Dimensions

Refer to pages 14-19-30 to 31.

Single Unit/Standard Dew Point -15°C Specifications

How to Order

IDG 10 H — **03** —

Flow rate by size

Size	Outlet air flow rate Purge air flow rate	ℓ/min(ANR)
3	25/3	
5	50/6	
10	100/11	
20	200/22	
30	300/35	
50	500/60	
60	600/65	
75	750/80	
100	1000/110	

Standard dew point temperature

Symbol	Standard dew point (°C)
H	-15

Thread type

Nil	Rc
N	NPT
F	G

Option

Symbol	Contents	Size									
		3	5	10	20	30	50	60	75	100	
Nil	None (Standard)	●	●	●	●	●	●	●	●	●	
P	With fitting for purge air discharge	●	●	●	●	●	●	●	●	●	
R	Flow direction (Right → Left)	●	●	●	●	●	●	●	●	●	
S	With dew point indicator	●	●	Standard equipment							

Note) In the case of two or more options, indicate them alphabetically.

Accessory

Nil	None (Standard)
B	With bracket

Note) When symbol B is indicated, a bracket assembly with a part number shown in the table below is included as an accessory.

Port size

Symbol	Bore	Size									
		3	5	10	20	30	50	60	75	100	
01	1/8	●	●	—	—	—	—	—	—	—	
02	1/4	●	●	●	●	●	●	—	—	—	
03	3/8	—	—	●	●	●	●	●	—	—	
04	1/2	—	—	—	—	—	—	●	●	●	



JIS Symbol

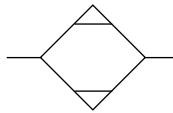

Standard Specifications/Single Unit Type (Standard dew point: -15°C)

Model		Standard dew point -15°C								
		IDG3H	IDG5H	IDG10H	IDG20H	IDG30H	IDG50H	IDG60H	IDG75H	IDG100H
Range of operating conditions	Fluid	Compressed air								
	Inlet air pressure (MPa)	0.3 to 0.85				0.3 to 1.0				
	Inlet air temperature (°C) ⁽¹⁾	-5 to 55				-5 to 50				
	Ambient temperature (°C)	-5 to 55				-5 to 50				
Standard performance	Outlet air atmospheric pressure dew point (°C)	-15								
Standard performance conditions	Inlet air flow rate (ℓ/min(ANR)) ⁽²⁾	28	56	111	222	335	560	665	830	1110
	Outlet air flow rate (ℓ/min(ANR))	25	50	100	200	300	500	600	750	1000
	Purge air flow rate (ℓ/min(ANR)) ⁽³⁾	3	6	11	22	35	60	65	80	110
	Inlet air pressure (MPa)	0.7								
	Inlet air temperature (°C)	25								
	Inlet air saturation temperature (°C)	25								
	Ambient temperature (°C)	25								
	Dew point indicator purge air flow rate	—		1 ℓ/min (ANR) {In the case of Inlet air pressure 0.7 MPa}						
	Port size (Nominal size B)	1/8, 1/4		1/4, 3/8			3/8, 1/2		1/2	
	Weight (kg) (With bracket)	0.25 (0.31)	0.43 (0.51)	0.66 (0.76)	0.74 (0.87)	0.77 (0.90)	1.50 (1.65)	1.50 (1.65)	1.55 (1.70)	

Note 1) No freezing.

Note 2) ANR indicates the flow rate converted to the value at 20°C under the atmospheric pressure and the state of relative humidity 65%.

Note 3) Includes 1 ℓ/min (ANR) of purge air flow (at 0.7 MPa inlet air pressure) for the dew point indicator (except IDG3H, 5H).

Bracket Assembly (Accessory) Part No.

Part no.	Applicable model
BM59	IDG3H/5H
BM61	IDG10H
BM63	IDG20H
BM64	IDG30H/50H
BM65	IDG60H/75H/100H

* With cap bolts and spring washers

Performance Chart

Conditions: Inlet air temperature 25°C (saturated air), Ambient temperature 25°C, P1: Inlet air pressure, Tube for purge air discharge (Option: P): None
 Notice: When using product with fittings for purge air discharge (Option: P) and if the tube length is 5 m or less, an increase of the outlet air dew point is 1°C or less.
 Product groups inside parentheses in the graph are classification symbols for selecting a model. (Refer to page 14-19-11.)

IDG3H (Type A products group)

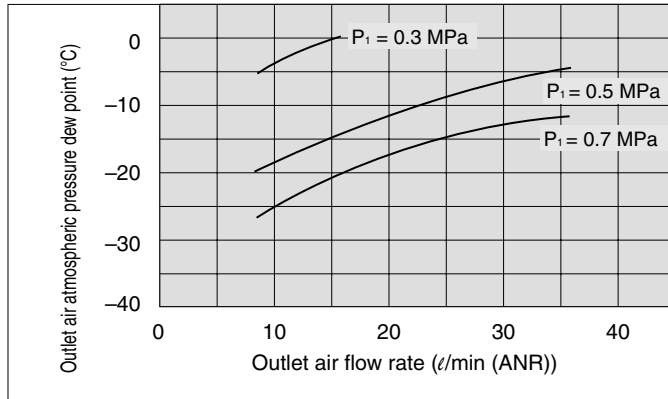

IDG5H (Type A products group)

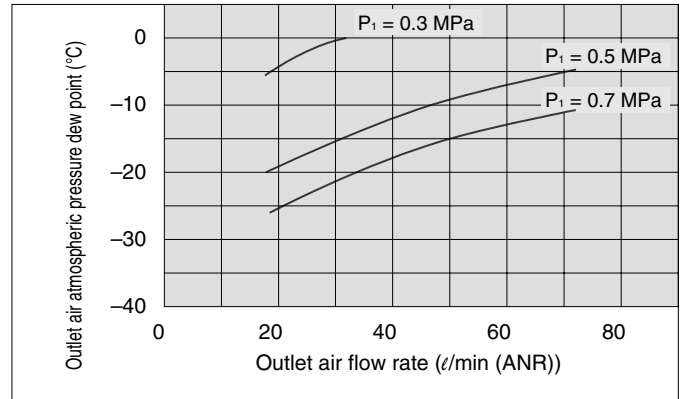

IDG10H (Type A products group)

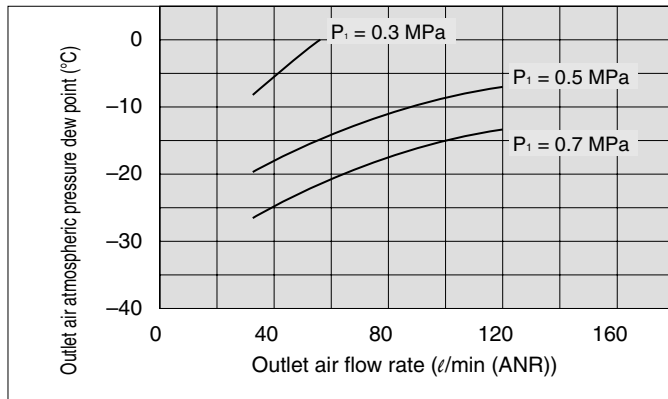

IDG20H (Type A products group)

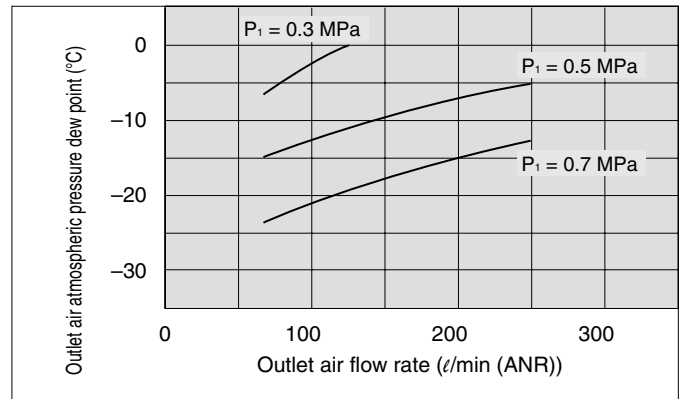

IDG30H (Type B products group)

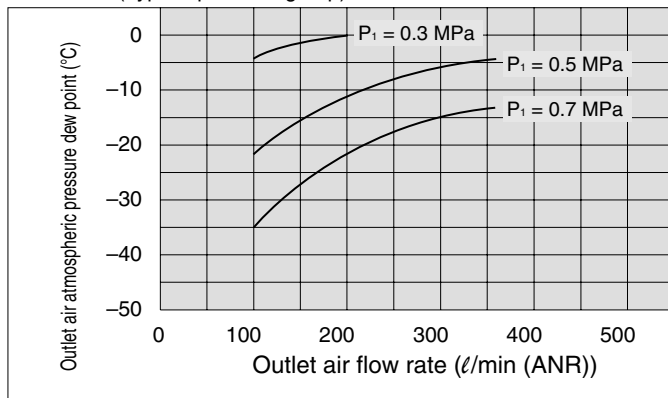

IDG50H (Type B products group)

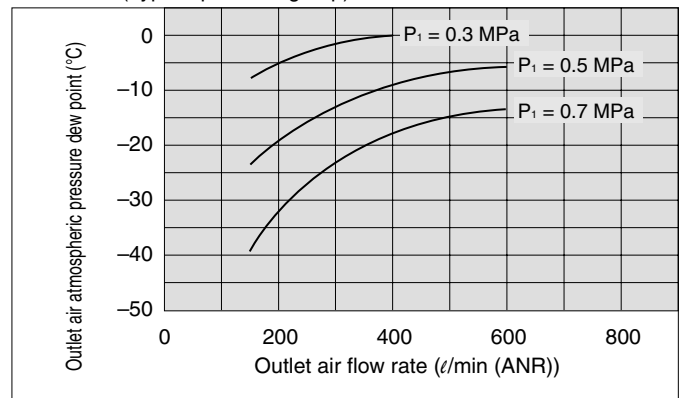

IDG60H (Type A product group)

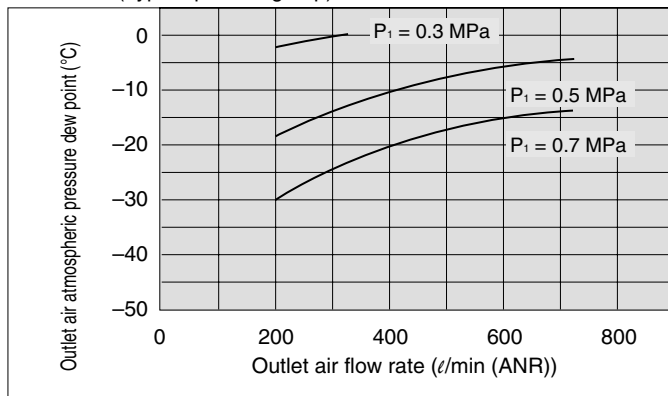

IDG75H (Type A products group)

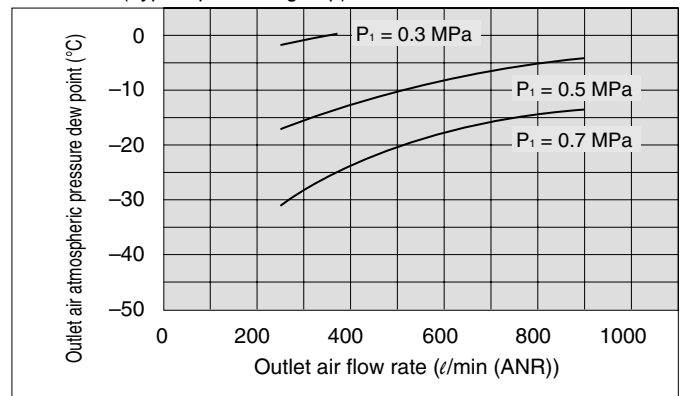

- HA
- AT
- ID
- AMG
- AFF
- AM
- Misc.

Series IDG

Performance Chart

Conditions: Inlet air temperature 25°C (saturated air), Ambient temperature 25°C, P₁: Inlet air pressure, Tube for purge air discharge (Option: P): None
Notice: When using products with fitting for purge air discharge (Option: P) and if the tube length is 5 m or less, an increase of the outlet air dew point is 1°C or less.

IDG100H (Type A products group)

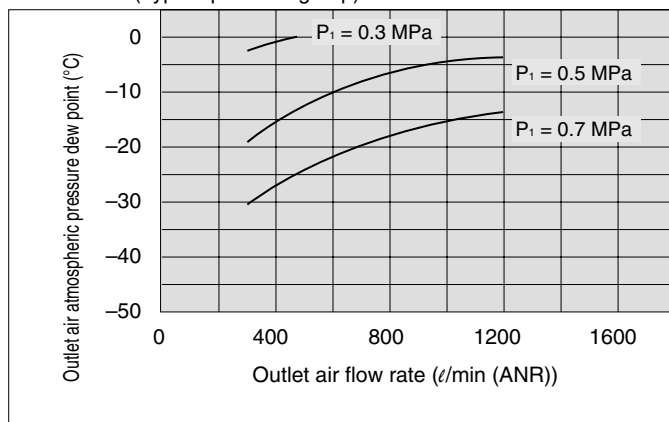

Construction

Refer to pages 14-19-28 to 29.

Dimensions

Refer to pages 14-19-30 to 31.

Single Unit/Standard Dew Point -40°C Specifications

How to Order

IDG **50** L — **03** —

Flow rate by size

Size	Outlet air flow rate Purge air flow rate ($\ell/\text{min}(\text{ANR})$)
30	75/25
50	110/40
60	170/57
75	240/80
100	300/100

Standard dew point temperature

Symbol	Standard dew point (N)
L	-40

Thread type

Nil	Rc
N	NPT
F	G

Port size

Symbol	Bore	Size				
		30	50	60	75	100
02	1/4	●	●	—	—	—
03	3/8	●	●	●	●	●
04	1/2	—	—	●	●	●

Option

Nil	None (Standard)
P	With fitting for purge air discharge
R	Flow direction (Right \rightarrow Left)

Note) In the case of two or more options, indicate them alphabetically.

Accessory

Nil	None (Standard)
B	With bracket

Note) When symbol B is indicated, a bracket assembly with a part number shown in the table below is included as an accessory.



IDG30L



IDG60L

JIS Symbol

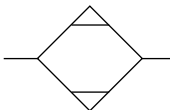

Standard Specifications/Single Unit Type (Standard dew point: -40°C)

Model		Standard dew point: -40°C				
		IDG30L	IDG50L	IDG60L	IDG75L	IDG100L
Range of operating conditions	Fluid	Compressed air				
	Inlet air pressure (MPa)	0.3 to 1.0				
	Inlet air temperature ($^{\circ}\text{C}$) ⁽¹⁾	-5 to 50				
	Ambient temperature ($^{\circ}\text{C}$)	-5 to 50				
Standard performance	Outlet air atmospheric pressure dew point ($^{\circ}\text{C}$)	-40				
	Inlet air flowrate ($\ell/\text{min}(\text{ANR})$) ⁽²⁾	100	150	227	320	400
Standard performance conditions	Outlet air flowrate ($\ell/\text{min}(\text{ANR})$)	75	110	170	240	300
	Purge air flowrate ($\ell/\text{min}(\text{ANR})$) ⁽³⁾	25	40	57	80	100
	Inlet air pressure (MPa)	0.7				
	Inlet air temperature ($^{\circ}\text{C}$)	25				
	Inlet air saturation temperature ($^{\circ}\text{C}$)	25				
	Ambient temperature ($^{\circ}\text{C}$)	25				
Dew point indicator purge air flow rate		1 ℓ/min (ANR) {In the case of Inlet air pressure 0.7 MPa}				
Port size (Nominal size B)		1/4, 3/8		3/8, 1/2		
Weight (kg) (With bracket)		0.74 (0.87)	0.77 (0.90)	1.50 (1.65)	1.65 (1.80)	1.80 (1.95)

Bracket Assembly (Accessory) Part No.

Part no.	Applicable model
BM64	IDG30L/50L
BM65	IDG60L/75L/100L

* With cap bolts and spring washers

Note 1) No freezing.

Note 2) ANR indicates the flow rate converted to the value at 20°C under the atmospheric pressure and the state of relative humidity 65%.

Note 3) Includes 1 ℓ/min (ANR) of purge air flow (at 0.7 MPa inlet air pressure) for the dew point indicator.

Performance Chart

Conditions: Inlet air temperature 25°C (saturated air), Ambient temperature 25°C P_i: Inlet air pressure, Tube for purge air discharge (Option: P): None
Product groups inside parentheses in the graph are classification symbols for selecting a model. (Refer to page 14-19-11.)

IDG30L (Type B products group)

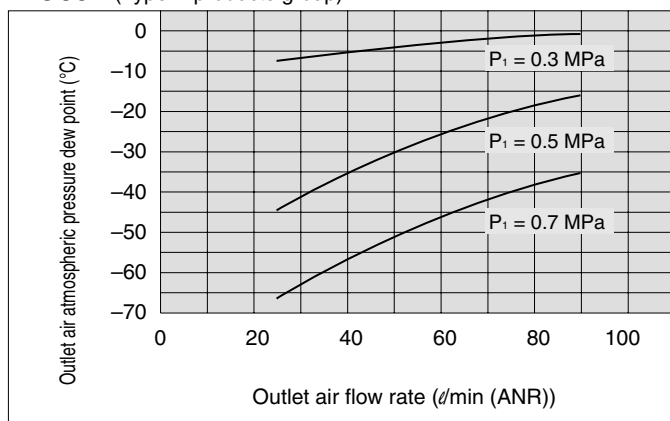

IDG50L (Type B products group)

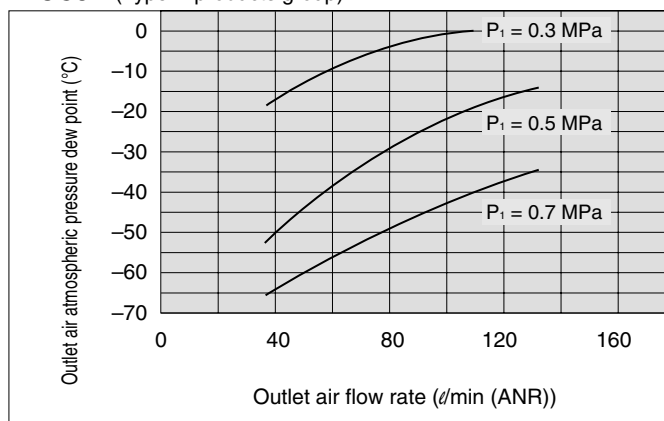

IDG60L (Type B products group)

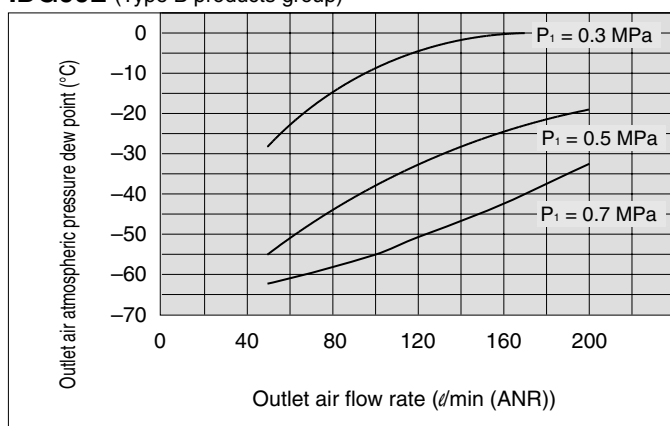

IDG75L (Type B products group)

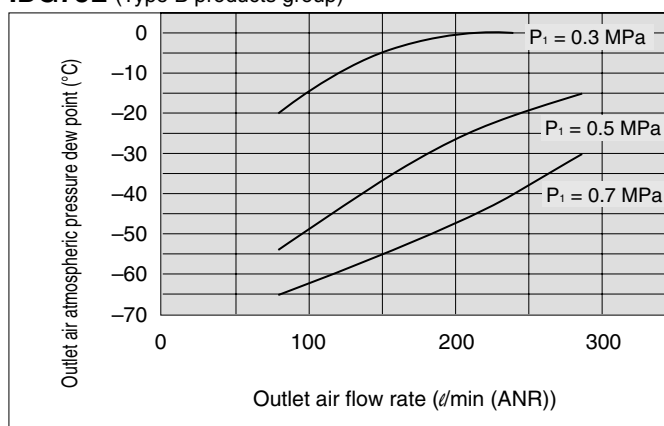

IDG100L (Type B products group)

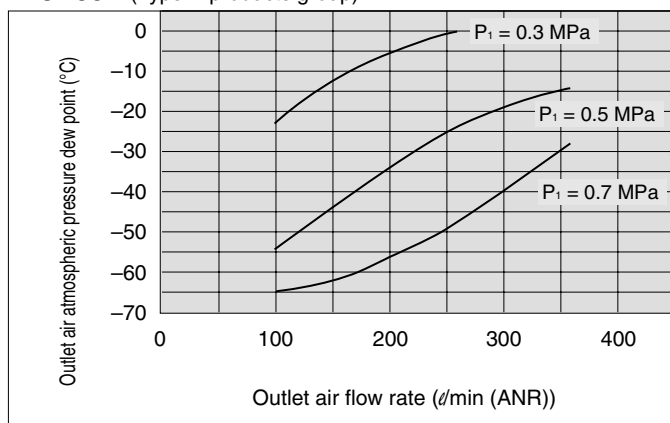

With fitting for purge air discharge (Option: P)

As the length of tubing for purge air discharge becomes longer, the outlet air atmospheric pressure dew point becomes higher. Refer to the table below.

Outlet Air at the Atmospheric Pressure Dew point in Compliance with the Tube Length for Discharging the Purged Air (°C)

Tube length	Model	IDG30L	IDG50L
0 m		-40	
1 m		-39	
3 m		-38	
5 m			

Note) In cases other than above model numbers, if the tube length is 5 m or less, an increase of the outlet air at the atmospheric pressure dew point will be 1°C or less.

Construction

Refer to pages 14-19-28 to 29.

Dimensions

Refer to pages 14-19-30 to 31.

HA

AT

ID

AMG

AFF

AM

Misc.

Conditions

Inlet air temperature : 25°C (Saturated)
Ambient temperature : 25°C
Inlet air pressure : 0.7 MPa
Outlet air flow rate : Flow gained under conditions of the standard performance. (Refer to page 14-19-24.)
Tubing size (O.D. x I.D.) mm: ø12 x ø9

Single Unit/Standard Dew Point –60°C Specifications

How to Order

IDG 60 S — 03 B

Flow rate by size

Size	Outlet air flow rate Purge air flow rate (#/min(ANR))
60	50/27
75	100/54
100	150/85

Standard dew point temperature

Symbol	Standard dew point (°C)
S	-60

Thread type

Nil	Rc
N	NPT
F	G

Port size

Symbol	Bore	Size		
		60	75	100
03	3/8	●	●	●
04	1/2	●	●	●

Option

Nil	None (Standard)
P	With fitting for purge air discharge
R	Flow direction (Right → Left)

Note) In the case of two or more options, indicate them alphabetically.

Accessory

Nil	None (Standard)
B	With bracket

Note) When symbol B is indicated, a bracket assembly with a part number shown in the table below is included as an accessory.



IDG60S

JIS Symbol

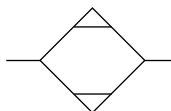

Bracket Assembly (Accessory) Part No.

Part no.	Applicable model
BM65	IDG60S/75S/100S

* With cap bolts and spring washers

Standard Specifications/Single Unit Type (Standard dew point: –60°C)

Model		Standard dew point: –60°C		
		IDG60S	IDG75S	IDG100S
Range of operating conditions	Fluid	Compressed air		
	Inlet air pressure (MPa)	0.3 to 1.0		
	Inlet air temperature (°C) ⁽¹⁾	– 5 to 50		
	Ambient temperature (°C)	– 5 to 50		
Standard performance	Outlet air atmospheric pressure dew point (°C)	– 60		
Standard performance conditions	Inlet air flow rate (#/min(ANR)) ⁽²⁾	77	154	235
	Outlet air flow rate (#/min(ANR))	50	100	150
	Purge air flow rate (#/min(ANR)) ⁽³⁾	27	54	85
	Inlet air pressure (MPa)	0.7		
	Inlet air temperature (°C)	25		
	Inlet air saturation temperature (°C)	25		
	Ambient temperature (°C)	25		
Dew point indicator purge air flow rate		1 ℓ/min (ANR) {In the case of Inlet air pressure 0.7 MPa}		
Port size (Nominal size B)		3/8, 1/2		
Weight (kg) (With bracket)		1.50 (1.65)	1.65 (1.80)	1.80 (1.95)

Note 1) No freezing.

Note 2) ANR indicates the flow rate converted to the value at 20°C under the atmospheric pressure and the state of relative humidity 65%.

Note 3) Includes 1 ℓ/min (ANR) of purge air flow (at 0.7 MPa inlet air pressure) for the dew point indicator.

Performance Chart

Conditions: Inlet air temperature 25°C (saturated air), Ambient temperature 25°C, P1: Inlet air pressure, Tube for purge air discharge (Option: P): None
 Notice: When using products with fitting for purge air discharge (Option: P) and if the tube length is 5 m or less, an increase of the outlet air dew point is 1°C or less. Product groups inside parentheses in the graph are classification symbols for selecting a model. (Refer to page 14-19-11.)

IDG60S (Type B products group)

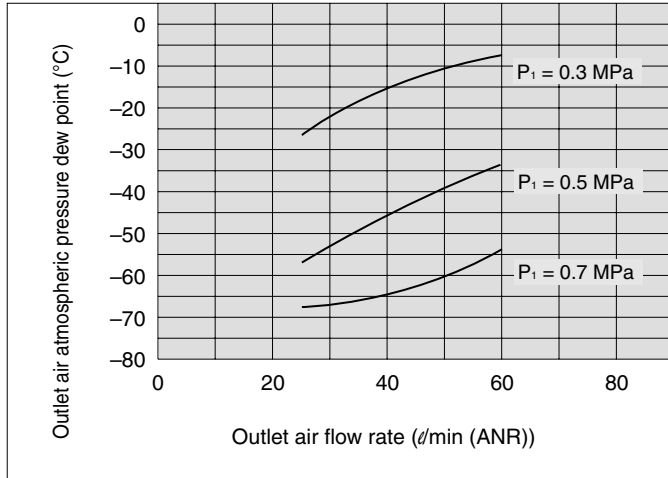

IDG75S (Type B products group)

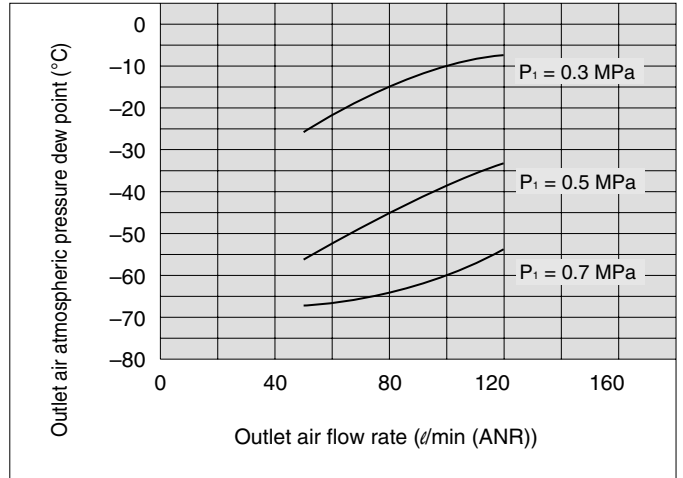

IDG100S (Type B products group)

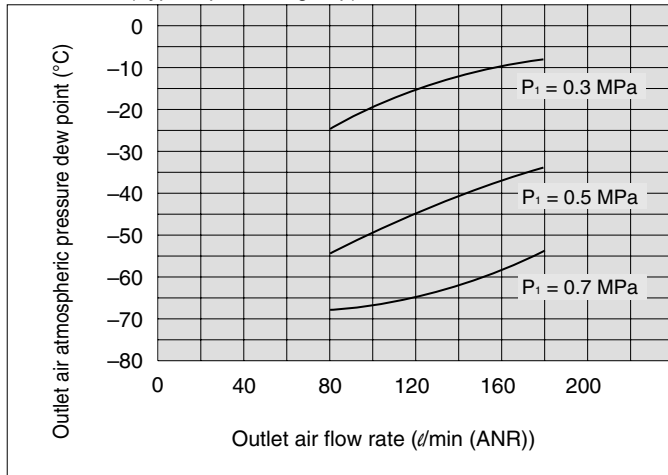

HA

AT

ID

AMG

AFF

AM

Misc.

Series IDG

Construction

IDG1

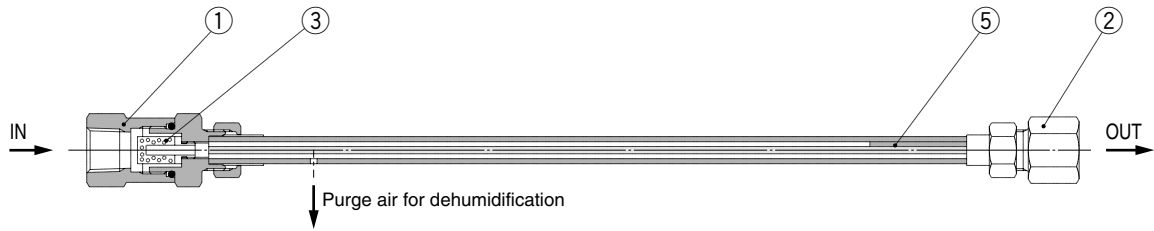

Option specifications With fitting for purge air discharge (Option: P)

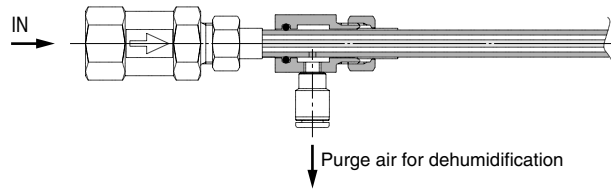

IDG3/5 IDG3H/5H

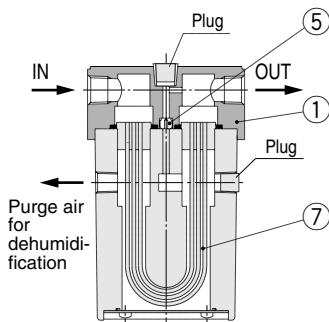

Option specifications With fitting for purge air discharge (Option: P)

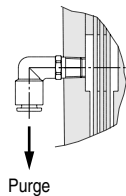

IDG10/20 IDG10H/20H

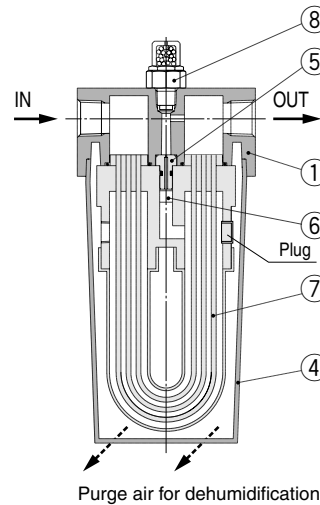

Option specifications With fitting for purge air discharge (Option: P)

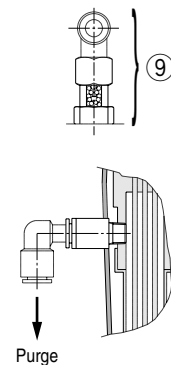

Component Parts

No.	Description	Material					Note
		IDG1	IDG3/3H	IDG5/5H	IDG10/10H	IDG20/20H	
①	Body	Copper alloy	Aluminum alloy			Platinum silver coated (IDG1 is electroless nickel plated.)	
②	Female connector	Copper alloy	—			Electroless nickel plated	
③	Strainer	Copper alloy	—				
④	Case	—	Resin				
⑤	Orifice	Resin	Stainless steel			IDG3H is resin.	
⑥	Silencer	—	Copper alloy				

Replacement Parts

No.	Description	Part no.					Note
		IDG1	IDG3/3H	IDG5/5H	IDG10/10H	IDG20/20H	
⑦	Membrane module kit	—	IDG-EL3 IDG-EL3H	IDG-EL5 IDG-EL5H	IDG-EL10 IDG-EL10H	IDG-EL20 IDG-EL20H	
⑧	Dew point indicator kit	—	IDG-DP01 (Option: S)		IDG-DP01		
⑨		—	IDG-DP01-X001 (Option: PS)		IDG-DP01-X001 (Option: P)		

IDG30/50
IDG30H/50H
IDG30L/50L

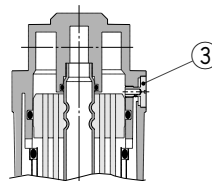
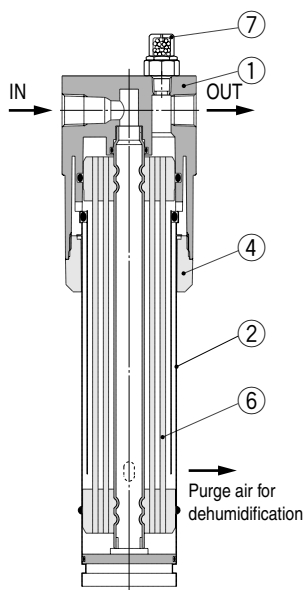

Option specifications
With fitting for purge
air discharge
(Option: P)

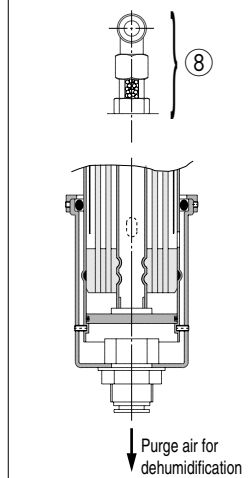

IDG60/75/100
IDG60H/75H/100H
IDG60L/75L/100L
IDG60S/75S/100S

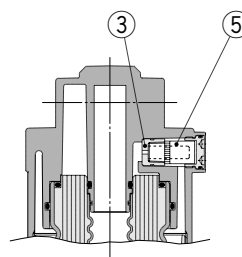
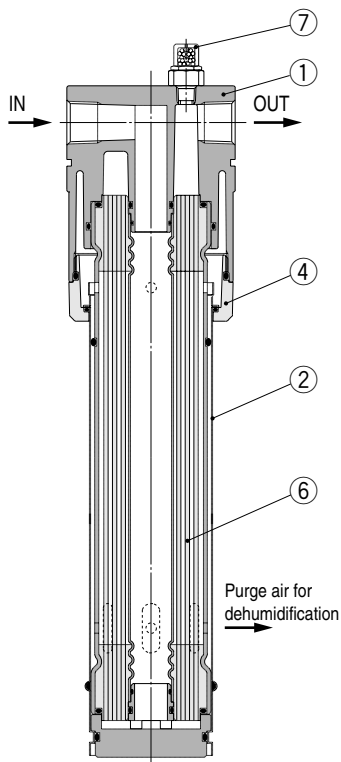

Option specifications
With fitting for purge
air discharge
(Option: P)

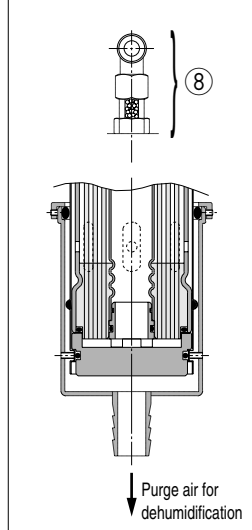

Component Parts

No.	Description	Material					Note
		IDG30/30H/30L	IDG50/50H/50L	IDG60/60H/60L/60S	IDG75/75H/75L/75S	IDG100/100H/100L/100S	
①	Body	Aluminum alloy					Platinum silver coated
②	Case	Stainless steel					
③	Orifice	Stainless steel					
④	Holder	Aluminum alloy		Aluminum			
⑤	Silencer	—		Resin + Copper alloy			

Replacement Parts

No.	Description	Part no.					Note
		IDG30/30H/30L	IDG50/50H/50L	IDG60/60H/60L/60S	IDG75/75H/75L/75S	IDG100/100H/100L/100S	
⑥	Membrane module kit	IDG-EL30	IDG-EL50	IDG-EL60 IDG-EL60L	IDG-EL75 IDG-EL75L	IDG-EL100 IDG-EL100L	
⑦	Dew point indicator kit	IDG-DP01					Option: P
⑧		IDG-DP01-X001					

HA

AT

ID

AMG

AFF

AM

Misc.

Series IDG

Dimensions

IDG1

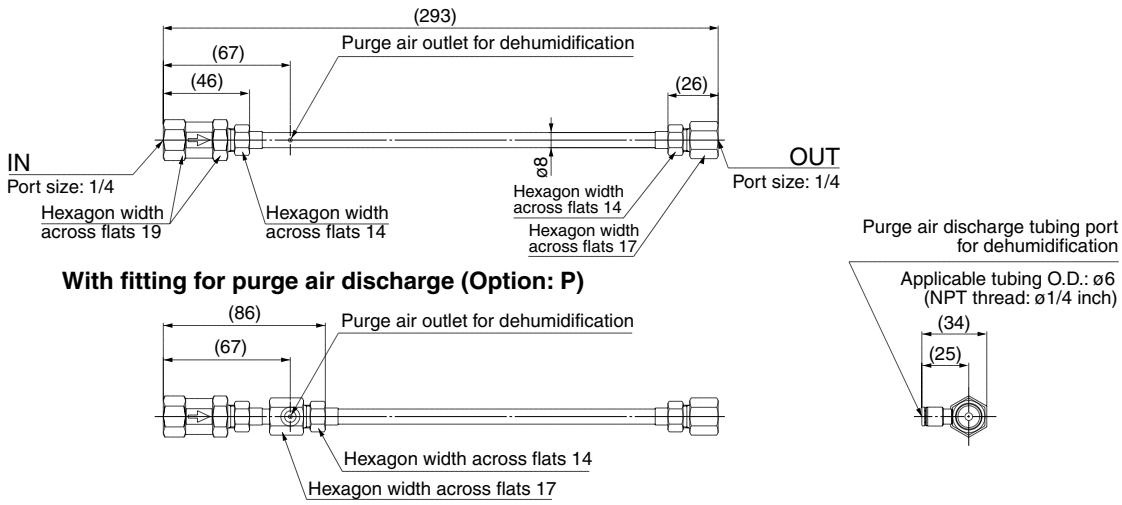

IDG3, 5 IDG3H, 5H

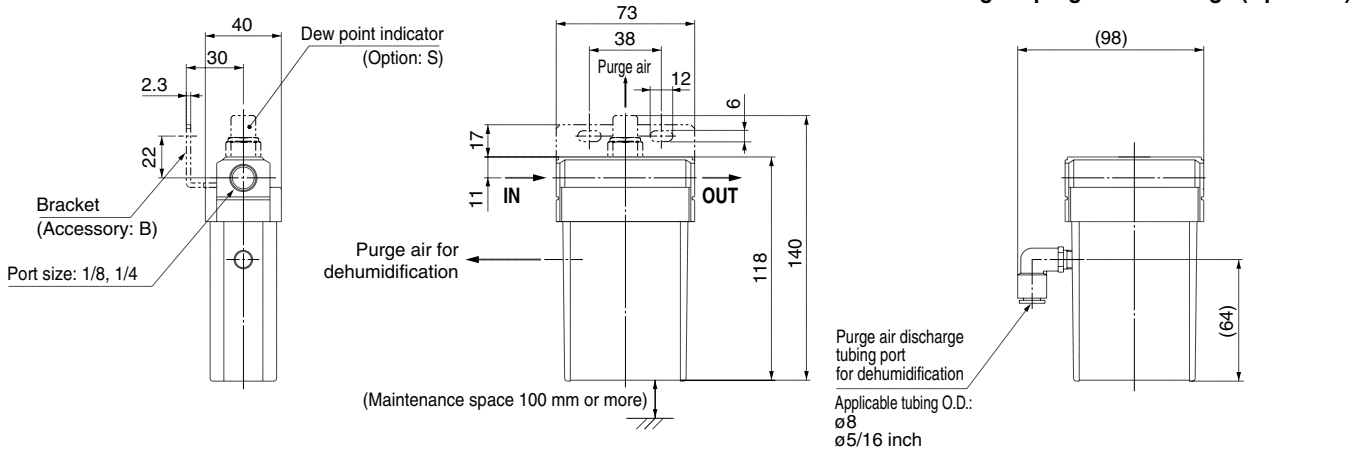

IDG10, 20 IDG10H, 20H

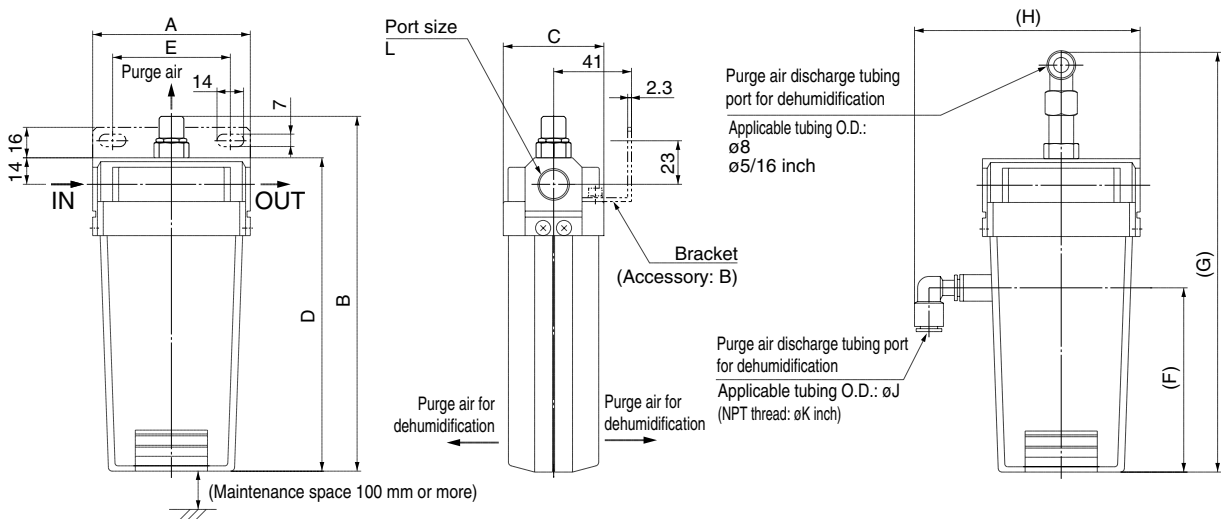

Model	Port size L	A	B	C	D	E	Option: P				
							F	G	H	J	K
IDG10/10H	1/4, 3/8	83	187	53	165	62	97	224	119 [126]	8	5/16
IDG20/20H		113	212	54	190	82	114	249	147 [154]	10	3/8

Values inside [] are for NPT threads.

Membrane Air Dryer Single Unit Type **Series IDG**

**IDG30/50
IDG30H/50H
IDG30L/50L**

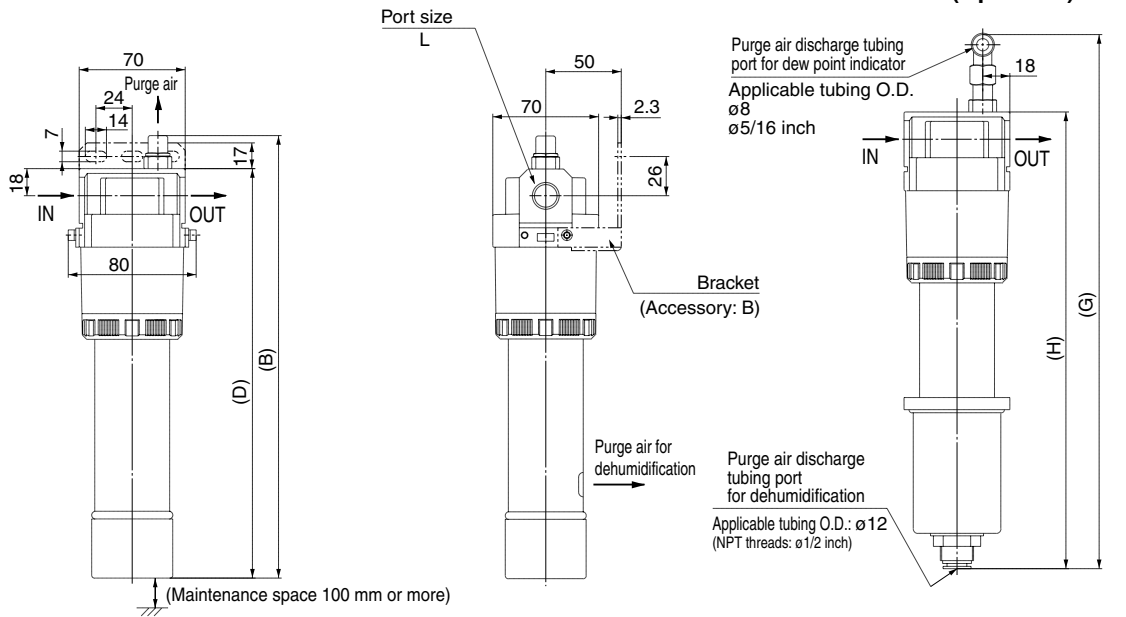

**IDG60/75/100
IDG60H/75H/100H
IDG60L/75L/100L
IDG60S/75S/100S**

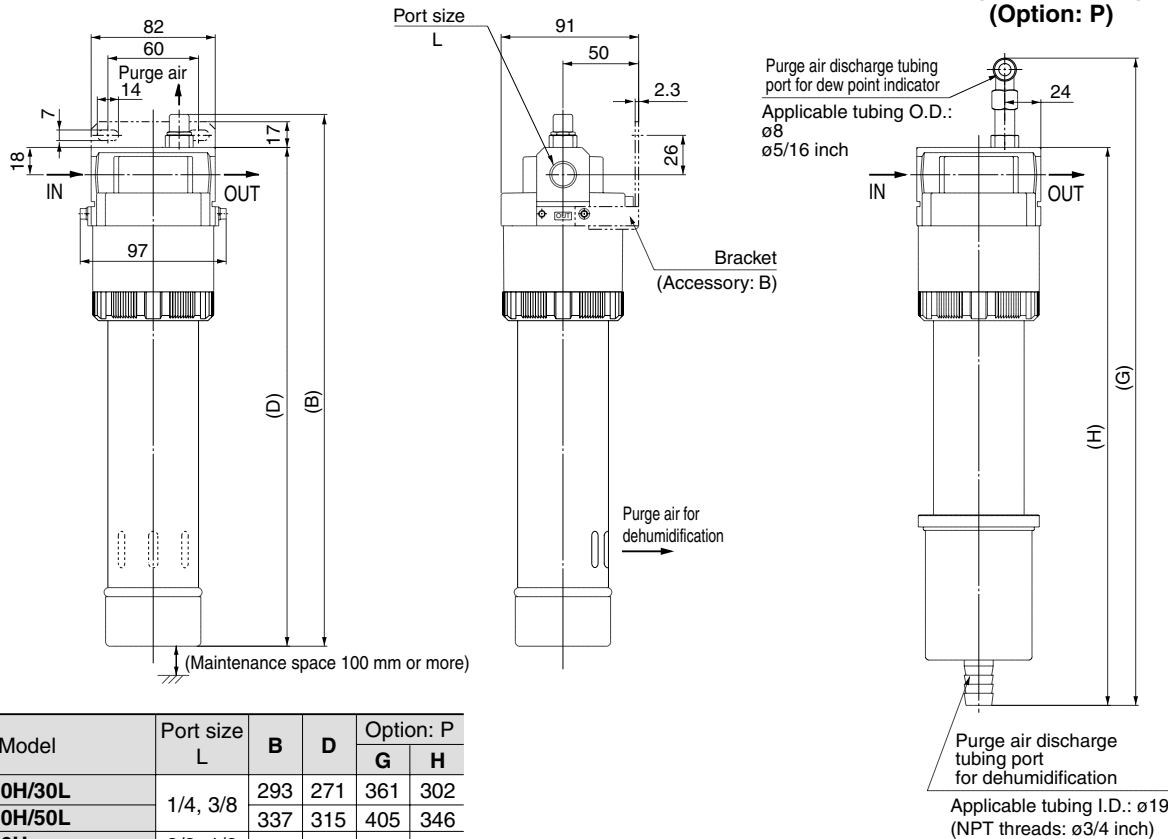

Model	Port size L	B	D	Option: P	
				G	H
IDG30/30H/30L	1/4, 3/8	293	271	361	302
IDG50/50H/50L		337	315	405	346
IDG60/60H	3/8, 1/2	352	330	428	369
IDG75/75H/100/100H		392	370	468	409
IDG60L/60S	3/8, 1/2	472	450	548	489
IDG75L/75S		542	520	618	559
IDG100L/100S					

- HA
- AT
- ID
- AMG
- AFF
- AM
- Misc.